

SENSOMAT

The Screwdriver with regulated clutch function

Seating torque from 0.3 – 5 Nm (3 – 44 in.lbs)

- Thread forming with maximum motor power
- Seating torque less than driving torque
- Thread forming instead of thread damaging
- Simple integration
- Smallest mounting dimensions

Our pneumatic screwdriver spindles SENSOMAT with mechanical clutch function are particularly suitable for applications such as:

- Sheet metal assemblies
- Wood assemblies
- Self-tapping through bolts

Screwdriver Spindles pneumatic



The SENSOMAT has been specially designed for screw joints where the screwdriving torque (forming torque) is close to or even higher than the shut-off torque due to high friction during assembly.

In this way for example thread forming or thread cutting screws can be reliably processed with this screwdriver which is equipped with a mechanical clutch lock – there is no chance of damaging the screw by over-tightening.

SENSOMAT – The Screwdriver with regulated clutch function

Sensomat

driving torque > seating torque (thread forming screw)

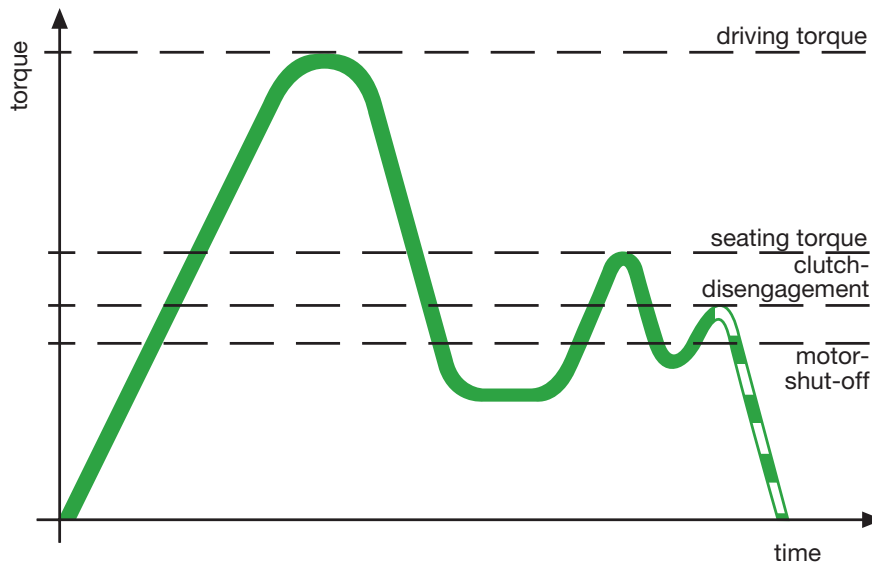

The SENSOMAT control screwdriver tightens the screw with full motor torque. Just before the base of the screw head is seated, the shut-off clutch is released and the screwdriver switches off exactly at the preset torque. The screw is completely screwed in without damaging the screw connection.

The SENSOMAT, a further development of the well-known MINIMAT screwdrivers achieves high torque accuracy and $\leq 3\%$ standard deviation with the help of the highly accurate shut-off clutch.

When used under the correct conditions DEPRAG pneumatic screwdrivers with shut-off clutch conform with a Cmk value of ≥ 1.67 with a tolerance requirement of 15% in relation to 6 Sigma according to ISO 5393.

In other words a Cmk value of 1.67 means that there is a failure rate of 0.6 per million screw assemblies.

TECHNICAL DATA SENSOMAT Motor Size 2

Screwdriver style		Motor Size 2		
Spindle, right-rotation, right shut-off Push-To-Start	Type	347S-228-31	347S-328-31	347S-528-31
	Part no.	391488A	391488B	391488C
Spindle, right-rotation, right shut-off Remote-Start	Type	347S-220-31	347S-320-31	347S-520-31
	Part no.	391489A	391489B	391489C
Seating torque, minimum	Nm / in.lbs	0.5 / 4.4	0.4 / 3.5	0.3 / 3
Seating torque, maximum	Nm / in.lbs	1.6 / 14	3 / 26	5 / 44
Driving torque, maximum	Nm / in.lbs	2 / 17.6	3.3 / 29	5.5 / 49
Speed, idling	rpm	4000	1550	680
Air consumption	m ³ /min / cfm	0.3 / 11	0.3 / 11	0.3 / 11
Diameter max.	mm / in.	27 / 1 ¹ / ₁₆	27 / 1 ¹ / ₁₆	27 / 1 ¹ / ₁₆
Length	mm / in.	245 / 9 ⁴¹ / ₆₄	245 / 9 ⁴¹ / ₆₄	245 / 9 ⁴¹ / ₆₄
Weight	kg / lbs	0.9 / 2	0.9 / 2	0.9 / 2
Push-to-start pressure	N / lbs	24 / 5	24 / 5	24 / 5
Pressure at max screwdriver stroke	N / lbs	100 / 22	100 / 22	100 / 22
Hose for air supply (O.D./I.D.)	mm / in.	8/5.5 (.314 / 7/32)	8/5.5 (.314 / 7/32)	8/5.5 (.314 / 7/32)
Hose for function control (O.D./I.D.)	mm / in.	4/2.5 (.157 / 3/32)	4/2.5 (.157 / 3/32)	4/2.5 (.157 / 3/32)
(O.D. tolerances of connection hoses according to Cetop PR54P)				
Internal hex. drive DIN ISO 1173		F6.3 (1/4")	F6.3 (1/4")	F6.3 (1/4")
Suitable tool inserts and connecting components with a drive as per DIN ISO 1173		E6.3 (1/4")	E6.3 (1/4")	E6.3 (1/4")
Quick change chuck, mounted		yes	yes	yes

Performance data relate to an air pressure of 6.3 bar (90 PSI)

Included in delivery:

Set of coupler and connector plug · Set of torque adjustment tools · Set of clutch springs

Suitable tool inserts → brochure D3320E

Motor Size 2
 Spindle
 right-rotation / right shut-off

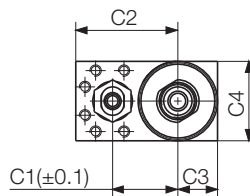
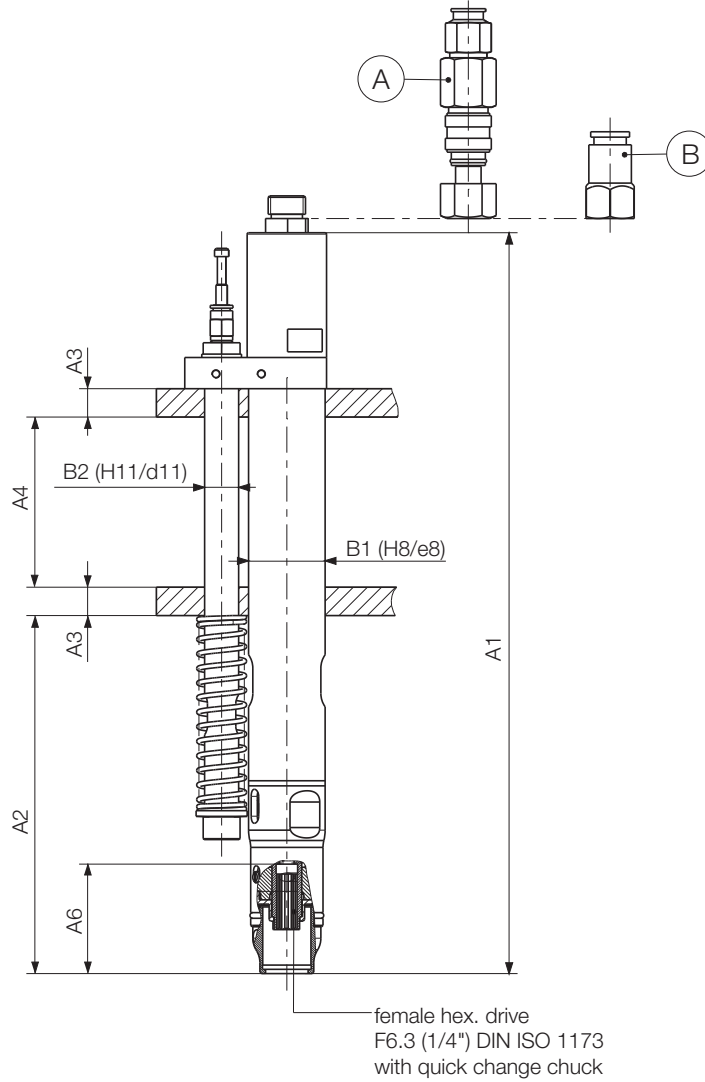

A = air supply for push-to-start
 B = air supply for start by remote valve

398821

Motor Size 2

Type			Dimensions (mm)											
			A1	A2	A3	A4	A5	A6	B1	B2	C1	C2	C3	C4
347S-228-31	347S-328-31	347S-528-31	261.25	126.25	10	60	-	38.6	27	12	23	36	14	28
347S-220-31	347S-320-31	347S-520-31	259	124.5	10	60	-	38.6	27	12	23	36	14	28

TECHNICAL DATA SENSOMAT Motor Size 3

Screwdriver style		Motor Size 3	
Spindle, right-rotation, right shut-off Push-To-Start	Type Part no.	346S-238-31 409280B	346S-738-31 409280C
Spindle, right-rotation, right shut-off Remote-Start	Type Part no.	346S-230-31 40929B	346S-730-31 409297C
Seating torque, minimum	Nm / in.lbs	0.5 / 4.4	0.5 / 4.4
Seating torque, maximum	Nm / in.lbs	4 / 35.4	5 / 44
Driving torque, maximum	Nm / in.lbs	4.5 / 40	7 / 62
Speed, idling	rpm	2500	1400
Air consumption	m ³ /min / cfm	0.45 / 16	0.45 / 16
Diameter max.	mm / in.	36 / 1 ¹³ / ₃₂	36 / 1 ¹³ / ₃₂
Length	mm / in.	264.5 / 10 ¹³ / ₃₂	264.5 / 10 ¹³ / ₃₂
Weight	kg / lbs	1.3 / 2.9	1.3 / 2.9
Push-to-start pressure	N / lbs	38 / 8	38 / 8
Pressure at max screwdriver stroke	N / lbs	116 / 26	116 / 26
Hose for air supply (O.D./I.D.)	mm / in.	10 / 7 (.422 / ¹⁷ / ₆₄)	10 / 7 (.422 / ¹⁷ / ₆₄)
Hose for function control (O.D./I.D.)	mm / in.	4 / 2.5 (.157 / ³ / ₃₂)	4 / 2.5 (.157 / ³ / ₃₂)
(O.D. tolerances of connection hoses according to Cetop PR54P)			
Internal hex. drive DIN ISO 1173		F6.3 (1/4")	F6.3 (1/4")
Suitable tool inserts and connecting components with a drive as per DIN ISO 1173		E6.3 (1/4")	E6.3 (1/4")
Quick change chuck, mounted		yes	yes

Performance data relate to an air pressure of 6.3 bar (90 PSI)

Included in delivery:

Set of coupler and connector plug · Set of torque adjustment tools · Set of clutch springs

Suitable tool inserts → brochure D3320E

Motor Size 3
 Spindle
 right-rotation / right shut-off

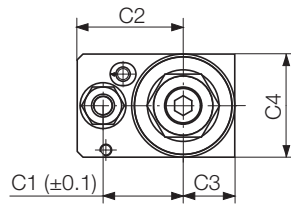
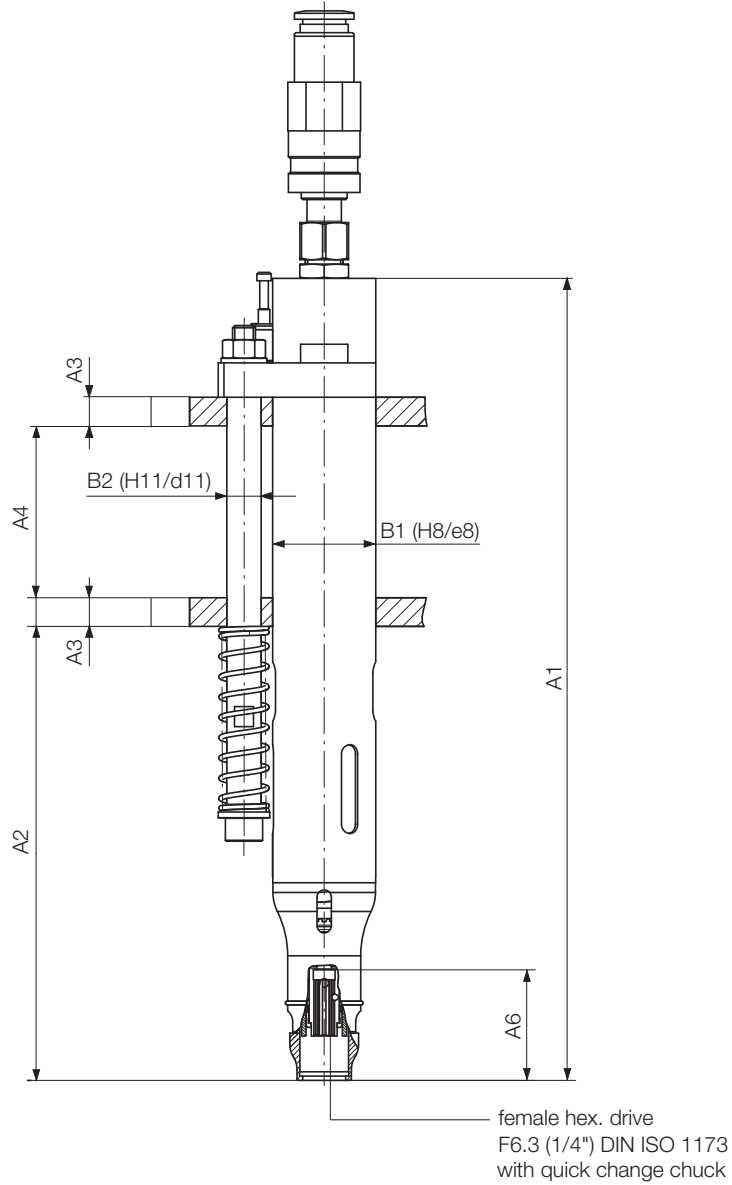

398041

Motor Size 3

Type		Dimensions (mm)											
		A1	A2	A3	A4	A5	A6	B1	B2	C1	C2	C3	C4
346S-238-31	346S-738-31	280	158.5	10	60	-	38.6	36	12	28	37	18	36
346S-230-31	346S-730-31	278	156.5	10	60	-	38.6	36	12	28	37	18	36

OPTIONAL EQUIPMENT

		Motor Size 2	Motor Size 3
Exhaust connection (vertical) ¹⁾ (connection piece with 2 m / 6.6 ft. hose)	Part no.	386924A	386924C
Exhaust connection (horizontal) ¹⁾ (connection piece with 2 m / 6.6 ft. hose)	Part no.	386924B	386924D
Depth control (double) incl. 2 cables (with straight plug) 5 m / 16.4 ft.	Part no.	on request	-
Sensor sleeve for screwdriver spindles with screwfeeding	Part no.	355311	355311
Sensor sleeve for screwdriver spindles without screwfeeding (see leaflet: Accessories D3320E, page 14 and 15)			
Adjustment bushing (for torque adjustment without sensor sleeve)	Part no.	461319	461319

¹⁾ for corresponding exhaust filter/silencer (see leaflet D 3340 E)

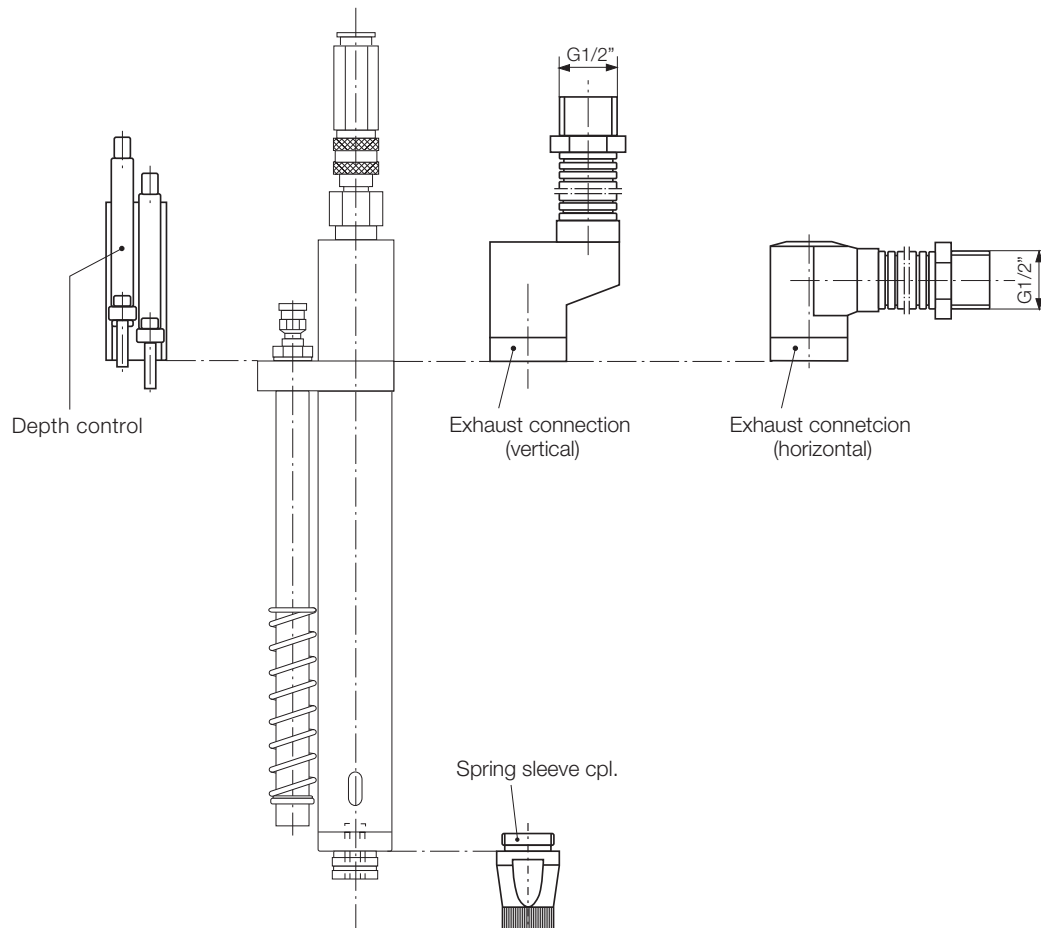

Push To Start

Driver with one way rotation,
right rotation and right shut-off

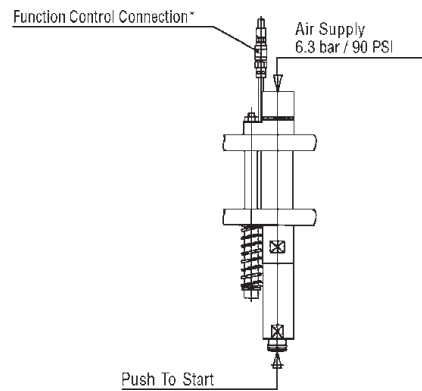

Remote Start (3/2-way valve)

Driver with one way rotation,
right rotation and right shut-off

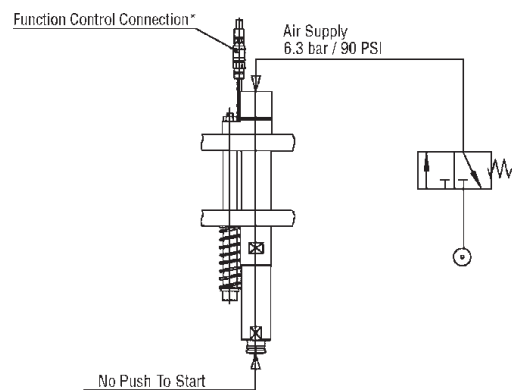

* During drive cycle the Function Control Line is under pressure (approx. 2 bar).

DEPRAG

DEPRAG SCHULZ GMBH u. CO.

P.O. Box 1352, D-92203 Amberg, Germany

Carl-Schulz-Platz 1, D-92224 Amberg

Phone (+49) 9621 371-0, Fax (+49) 9621 371-120

www.deprag.com

info@deprag.de

CERTIFIED AS PER DIN EN ISO 9001
